



Automated Medicine Dispenser in Pharmacy

Dr.Sivakumar Sabapathy Arumugam

Assistant Professor, Department of ECE, Info Institute of Engineering, Coimbatore, India
Email: siva3cool@gmail.com

Priyanka Dhanapal

UG Scholar, Department of ECE, Info Institute of Engineering, Coimbatore, India
Email: priyankadhanapal1997@gmail.com

Nandhini Shanmugam

UG Scholar, Department of ECE, Info Institute of Engineering, Coimbatore, India
Email: nandhinishanmugam016@gmail.com

Indumathi Balasubramaniam

UG Scholar, Department of ECE, Info Institute of Engineering, Coimbatore, India
Email: indum843@gmail.com

Pavithra vijayakumar

UG Scholar, Department of ECE, Info Institute of Engineering, Coimbatore, India
Email: pavithravijayakumar15@gmail.com

Abstract: *Automatic medicine dispenser is designed specifically to reduce manpower and shopping time in pharmacy. Normally when we go to pharmacies, we have to wait for a long time to get our medicines. Hence this project mainly concentrates to avoid the problem. The purpose of the experiment is to deliver the medicine to the customer in minimum time. The system is proposed using embedded systems and PROTEUS software. The detailed working of dispenser machine is demonstrated in this paper.*

Keyword: *Automatic medicine dispenser; pharmacy; medicine; PROTEUS.*

1. INTRODUCTION

Now-a-days in this fast moving world, appliances that are completely automatic are preferred. Automation plays a major role in every day to day activities, industries and medical areas. The major problem faced in pharmacy is it takes long time to dispatch the medicine required by the customer. Even though there might be separate counters for billing and delivery, this process becomes more tedious in case of emergency.

In order to overcome this issue, an automatic medicine dispenser machine is developed which helps in identifying the exact medicine rack and pharmacist can dispatch the medicine more quickly. There is no doubt that these machines can enhance the efficiency of medication distribution. This is particularly important in emergency departments and intensive care units in hospitals for immediate access. The system is

Cite this paper:

Sivakumar Sabapathy Arumugam, Priyanka Dhanapal, Nandhini Shanmugam, Indumathi Balasubramaniam, Pavithra Vijayakumar, "Automated Medicine Dispenser Machine In Pharmacy", International Journal of Advances in Computer and Electronics Engineering, Vol. 4, No.8, pp. 6-11, August 2019.

fully controlled by the ARDUINO-UNO micro controller. Automated dispensing machines decentralized medication distribution systems that provide computer-controlled storage, dispensing, and tracking of medications. Automated dispensing machines provide secure medication storage on patient care units. This is the biggest advantage of this project.

2. EXISTING METHOD WORKING METHODOLOGY

2.1 Touch Screen Based Automated Medicine Vending Machine

The main idea of this system is to provide medical facilities in certain areas like highways, long route trains, and rural areas. This system uses IR standard technology, power supply, microcontroller, motor driver, GSM and GPS. The features are, it has both medicine dispenser and medical services. Medical services includes ambulance, hospital location, and to call doctor [1]. The method of medicine dispenser includes the following steps,

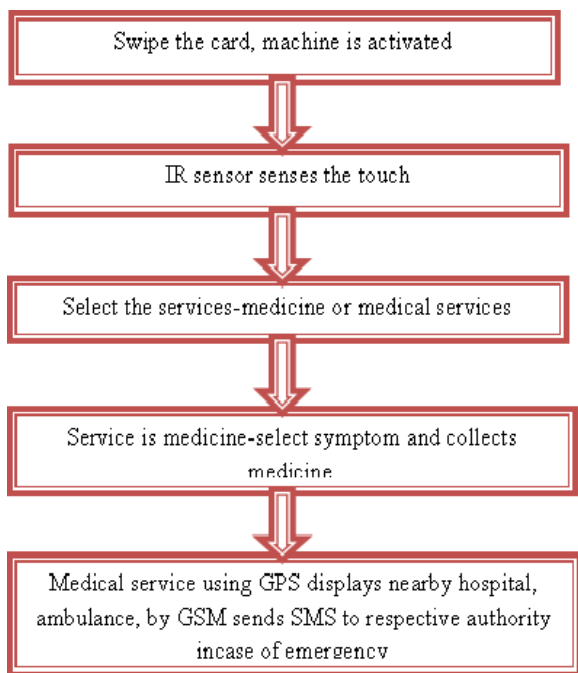

Figure 1 Touch screen based automated medicine vending machine

2.2 Smart Medicine Dispenser

Now a day, taking medicine at the right time still remains a problem for everyone, mainly for Geriatrics. Hence, this paper mainly concentrates in solving this problem by notifying the patients at the right time to take their medicines with correct dosages. This machine has a Microcontroller, a LCD display, Real Time Clock (RTC) module [2], GSM module and an alarm system in order to intimate the patients to take their dosages at the right time.

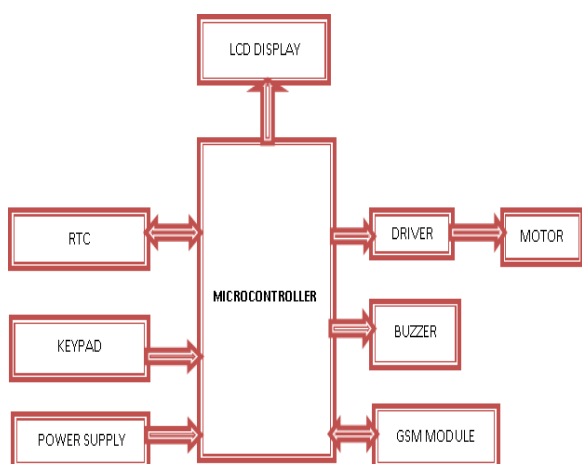

Figure 2 Smart medicine dispenser

2.3 Automated Medicine Dispensing Machine

Automated medicine dispensing machine is used to take care of the aged one. The machine contains the

microcontroller, which plays the major role. The aged persons take their medicines by themselves without the help of their family members. The patients should have the RFID tag, and then they should keep their tag in front of the machine.[3]Then the machine scans the patients tag and delivers the medicine.

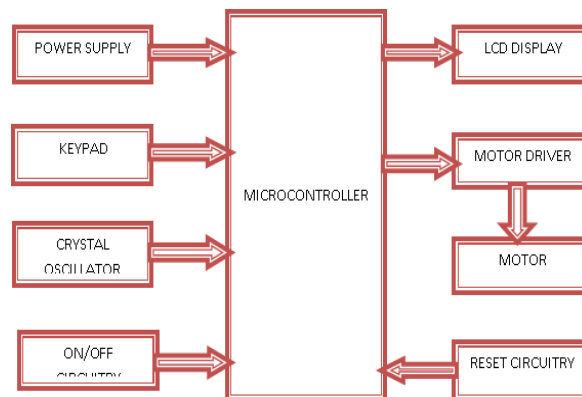

Figure 3 Automated medicine dispensing machine

2.4 Robotic Pill Dispenser

Most often people whether they are old or young forget their medicines. Medication on time is very important for the cure of any disease. An automatic pill dispenser with the ability to distribute multiple pills for a certain patient allows more attention to be given to patients and elderly to remember when and what dosage of their medication has to be taken. The main concept of our project is the pill dispenser which is the model of a circular drive which has four sections to place the medicine for a day. Our project uses PIC microcontroller .The dispenser also has a LCD display to display the medication system and medication time is alerted by the alarm.[4]The Whole pill dispenser is movable which is controlled by a remote control.

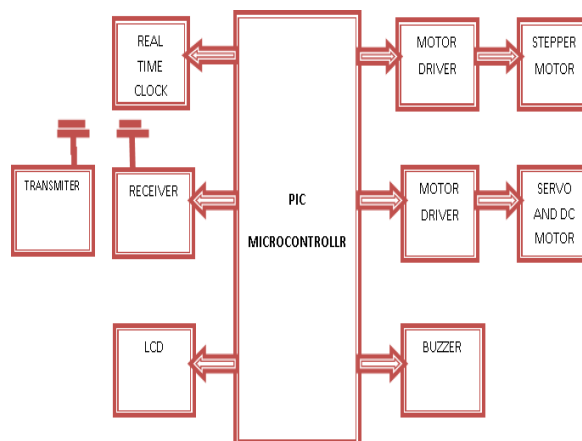

Figure 4 Robotic pill dispensers

3. PROPOSED METHOD WORKING METHODOLOGY

In the proposed method, the RFID technology is incorporated into systems used for tracking technology and authentication. This technology uses radio waves to identify objects and people. By this system we can improve efficiency by lowering manpower. The proposed model not only aids the customer but also saves lot of time. The RFID card is given to patients in which the prescription is pre-loaded. Then these cards are read and accordingly the respective medicine trays are opened to minimize the efforts of the pharmacists to go in search of medicine from rack to rack. The working of this proposed technique is illustrated as follows:

Initially the information of the patient is pre-loaded in the RFID tag and the RFID reader is used to read the information in the RFID tag. These data are being processed and the respective medicine tray gets opened. Through LCD the details are displayed and by GSM module the total billing amount is transmitted to the user's mobile phone.

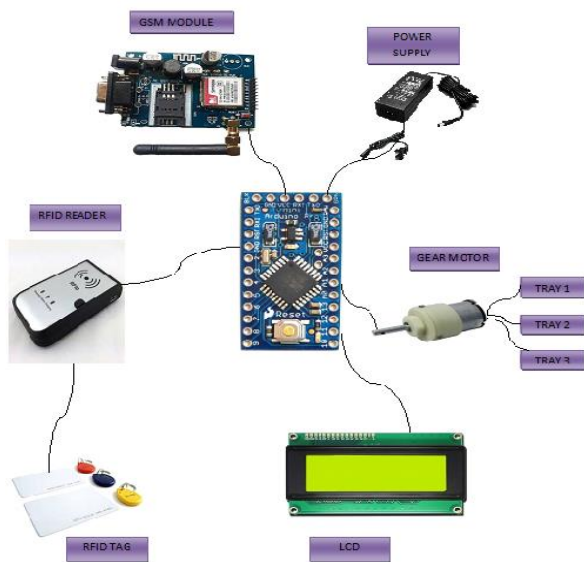

Figure 5 Block diagram

4. MATERIALS&METHODS

4.1 Power Supply

Power supply is an electrical device that supplies electrical power to an electrical load. The primary function of a power supply is to convert electric current from a source to the correct voltage, current and frequency to power the load. As the result, power supplies are sometimes referred to as electric power converters. Some power supplies are separate standalone pieces of equipment, while others are built into the load appliances that they power. Examples of the later include power supplies found in desktop computers and consumer electronics devices. Other

functions that power supplies may perform include limiting the current drawn by the load to safe levels, shutting off the current in the event of an electrical fault.



Figure 6 Power supply

4.2 LCD

Liquid crystal display is a flat-panel display or other electronically modulated optical device that uses the light modulating properties of liquid crystals. Liquid crystals do not emit light directly, instead using a backlight or reflector to produce images in color or monochrome. LCDs are available to display arbitrary images(as in a general-purpose computer display) or fixed images with low information content, which can be displayed or hidden, such as preset words, digits, and seven-segment displays, as in a digital clock.



Figure 7 LCD

4.3 Arduino-Promini

The Arduino Pro Mini is a microcontroller board based on the ATmega328 .It has 14 digital input/output pins (of which 6 can be used as PWM outputs pins), 6 analog inputs,an on-board resonator ,a reset button , and holes for mounting pin headers. A six pin header can be connected to an FTDI cable or sparkfun breakout board to provide USB power and communication to the board. Arduino pro mini is intended for semi-permanent installation in objects or exhibitions.



Figure 8 Arduino promini

4.4 GSM

GSM is a standard development by the European telecommunication standards institute to describe the protocols for second –generation digital cellular networks used by mobile devices such as tablets. It was first developed in Finland in December 1991. As of 2014, it has become the global standard for mobile communications-with over 90% market share, operating in over 193 countries and territories.

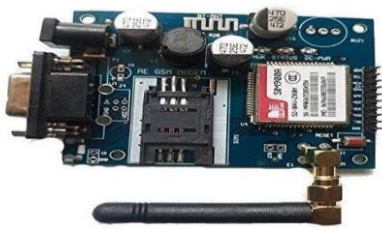

Figure 9 GSM module

4.5 Gear Motor

Gear motors are a fairly well-established technology. Gear motors are most often used in applications that need a lot of force to move heavy objects. Gear motors are commonly used in devices such as can openers, garage door openers, washing machine time control knobs, and even electric alarm clocks. Common commercial jacks, and cranes. Regardless of what type of gear motor you’re dealing with, they all work in the same manner.



Figure 10 Gear motor

4.6 RFID Tag

Radio frequency identification (RFID) uses electromagnetic fields to automatically identify and track tags attached to objects. The tag contains electrically stored information. RFID tag can be attached to cash, clothing and possessions, or implanted in animals and people , the possibility of reading personally-linked information without consent has raised serious privacy concerns. RFID is one method of automatic identification and data capture (ADIC).



Figure 11 RFID Tag

4.7 RFID Tag Reader

This reader is used to gather information from an RFID tag, which is used to track individual objects. Radio waves are used to transfer from the tag to a reader. RFID is a technology similar in theory to bar codes. However, the RFID tag does not have to be scanned directly, nor does it require line-of-sight to a reader. The RFID tag it must be within the range of an RFID reader, which ranges from 3 to 300 feet in order to be read.



Figure 12 RFID Reader

5. SOFTWARE OUTPUT

The Proteus Design Suite is a proprietary software tool suite used primarily for electronic design automation. The software is used mainly by electronic design engineers and technicians to create schematics and electronic prints for manufacturing printed circuit boards. The simulation result displaying the working of automated medicine dispenser is shown below.

Here initially the RFID reader reads and gives the input to the receiver of arduino microcontroller. By using this information the process details are displayed in LCD. The motor driver that is attached to the motor connected to the microcontroller drives the motor in order to open the respective medicine trays. And finally the GSM module gets the details from the Transmitter of the microcontroller.

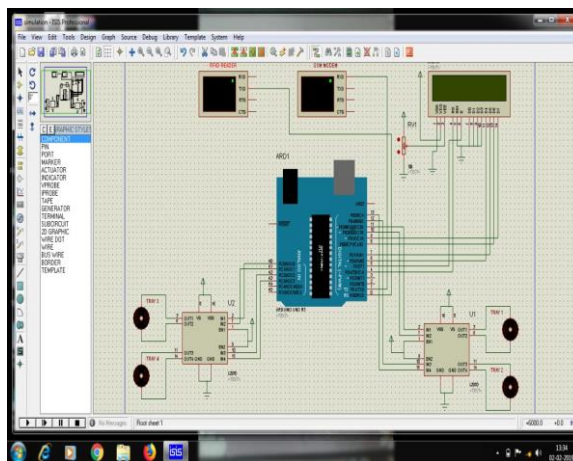

Figure 13 simulation output

6. CONCLUSION

After examining the survey papers on various medicine dispensing machines such as touch screen based automated medicine vending machines, smart medicine dispenser, automated medicine dispensing machine and a robotic pill dispenser, an automated medicine dispenser that works by taking inputs from an RFID technology that uses radio waves to identify objects, datas ,etc., is proposed. The proposed system improves the efficiency by lowering the manpower. The future enhancements are given below; Pill cutting strategy accessing the website by using IOT

REFERENCES

- [1] SurajShinde, NitinBange, Monika Kumbhar and SnehalPatil, "Smart Medication Dispenser", International Journal of Advanced Research in Electronics and Communication Engineering (IJARECE), Volume 6, Issue 4, pp. 200-204, April 2017.
- [2] Prisilalshabakaki and ShubiKaijage "RFID-based Drug Management and Monitoring System, Case of Public Hospitals in Tanzania, A Review Paper", Computer Engineering and Applications, Volume 4, Issue 3, pp. 165-171,September 2015.
- [3] Lindsay Enzor, "Use of RFID in the Pharmacy and Beyond", Medication Tracking software, Volume 13, Issue No. 6, pp. 1-20, June 2016.
- [4] Eric Becker, Roman Arora and Vangelis Metsis, "SmartDrawer: RFID-based smart medicine drawer for assistive environments", Proceedings of the 2nd International Conference on Pervasive Technologies Related to Assistive Environments, January 2009.
- [5] McCall C, Maynes B, Zou CC and Zhang NJ, "RMAIS: RFID-based medication Adherence Intelligence System", Conference Proceedings IEEE Engineering Medicine Biological Society, Volume 3768, Issue 71, 2018.
- [6] Po-Jen Chen , Yung-Fu Chen, Sin-Kuo Chai and Yung-Fa Huang, "Implementation of an RFID-based management system for operation room", Proceedings of International Conference on Machine Learning and Cybernetics, 2009.
- [7] Dr.Naveen Raman, Sivakumar Sabapathy Arumugam, Munuswamy Cholavendan, Thiyagarajan aswini, Santhana Krishnan Koushika, Velusamy Elango, RamaKrishnan Elangovan "E-Health Card With Patient Monitor Using Wireless Sensor", International Journal of Advances in Computer and Electronics Engineering, Vol. 3, No. 8, pp. 1-8, August 2018.
- [8] S. Mukund, N. K. Srinath, " Design of automatic medication dispenser", International conference of advanced computer science and information technology, Volume.no.2, issue no.11, pp. 251-257, 2012.
- [9] M. Sangeetha, T V Janardhana rao, Ch S Rama Gowri, "Automatic medicine vending system-medical ATM", International journal of scientific development and research (IJSDR), Volume no.1, Issue no.10, pp 185-190, October 2016.
- [10] Dhanu shree, Anuradha J P, Nitin awasthi, "Automatic medicine dispenser for hospitals and old age homes", International research journal of engineering and technology (IRJET), Volume no.5, Issue no.4, pp 4955-4958, April 2018.

Authors Biography



Dr.Sivakumar Sabapathy Arumugam has a B.E., degree in ECE and M.E., degree in VLSI Design and working as Assistant Professor at Info Institute of Engineering Coimbatore-India. He is pursuing his Research in Anna University- Chennai. His areas of interests are VLSI design

and embedded systems.



Priyanka Dhanapal is pursuing B.E., degree in ECE at Info Institute of Engineering Coimbatore-India. Her areas of interests are Wireless Sensor and embedded systems.



Nandhini shanmugam is pursuing B.E., degree in ECE at Info Institute of Engineering Coimbatore-India. Her areas of interests are Wireless Sensor and embedded systems.



Indumathi balasubramaniam is pursuing B.E., degree in ECE at Info Institute of Engineering Coimbatore-India. Her areas of interests are Wireless Sensor and embedded systems.



Pavithra vijayakumar is pursuing B.E.,degree in ECE at Info Institute of Engineering Coimbatore-India. Her areas of interests are Wireless Sensor and embedded systems.

**Cite this paper:**

Sivakumar Sabapathy Arumugam, Priyanka Dhanapal, Nandhini Shanmugam, Indumathi Balasubramaniam, Pavithra Vijayakumar, "Automated Medicine Dispenser Machine In Pharmacy", International Journal of Advances in Computer and Electronics Engineering, Vol. 4, No.8, pp. 6-11, August 2019.